

■ Gantry Welding Systems



■ TYPES OF BEAMS:

- with closed section
- with T-section
- with I-section
- HSI and HSQ beams

■ TYPICAL WORK SPACE:

(to be customized)

- 1.200 mm vertically
- 1.200 mm horizontally
- Length of track - 18,5 m
- Length of welding - 16 m

■ MAIN TECHNICAL DATA:

- Speed of X axis movement: from 0,01 up to 10 m/min.
- The standard version comprises 5 numerically controlled axes, controlled by a computer system with TFT graphic display
- Active compensation of position of both torches with regard to the welding seam with precision of 0,1 mm
- Control system menu in English

MOST OF TECHNICAL SPECIFICATIONS CAN BE CUSTOMIZED. ONE OF PROMOTECH'S MAIN ADVANTAGES IS ITS CAPACITY TO MANUFACTURE PURPOSE DESIGNED AND CUSTOM BUILT SYSTEMS.

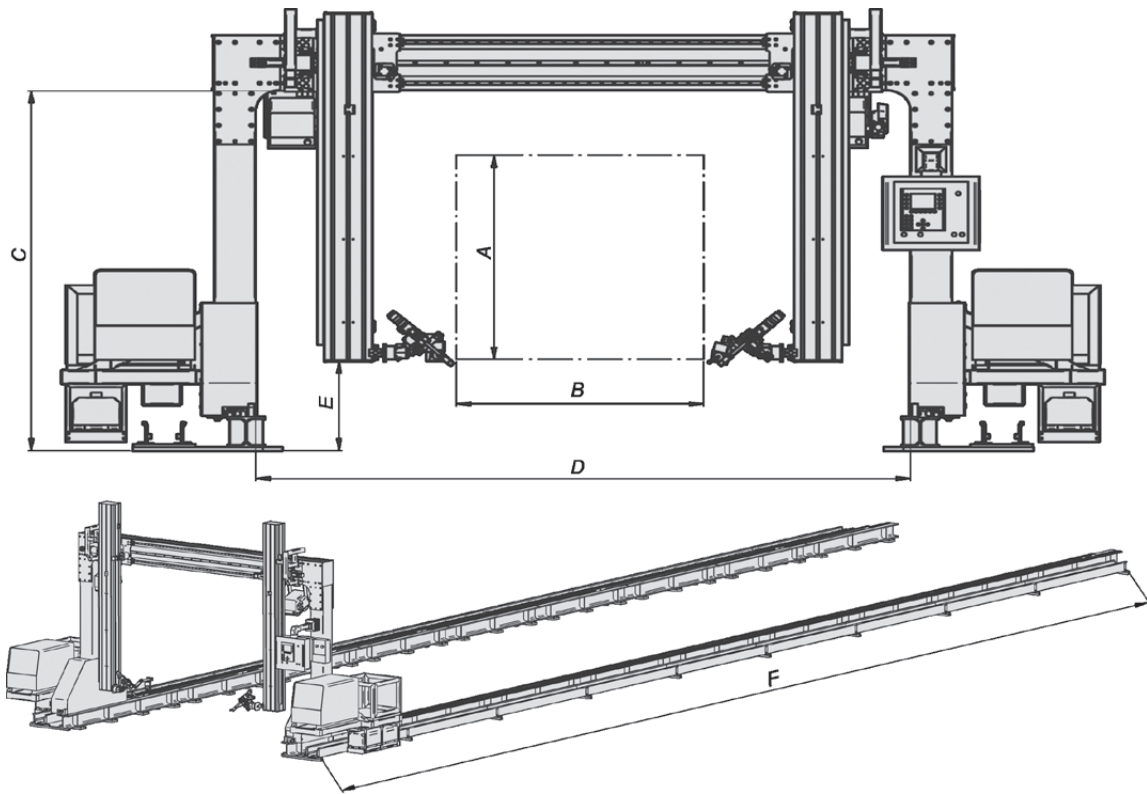

GWS Type/Size	GWS 1200/1200	GWS 1500/1500	GWS 1500/2500	GWS 1800/3300
A x B [mm]	1200 x 1200	1500 x 1500	1500 x 2500	1800 x 3300
C x D [mm]	2000 x 3100	2300 x 3500	2300 x 4500	2600 x 5500

Size E (600 mm most common) and size F (18.500 mm most common) to be agreed with customer

■ MAIN FEATURES:

- GWS is controlled by digital controller
- The system comprises a high-precision maintenance-free, planetary gearbox
- All axes are powered by high-class servo motors
- Every servo motor is controlled by a digital inverter
- High-precision linear guides ensure precise and smooth motion of all system axes
- The torch holders are fitted on machine's supports through anti-collision joints
- Rigid and heavy duty construction is based on aluminium section profiles
- GWS is equipped with active safety systems enable protection of the staff
- System software can be customized to the customer's welding technology
- Depending on a type of welding equipment there is a possibility of registration of welding parameters like current and voltage in a function of time
- Visual seam tracking system and remote control is available upon request

■ GENERAL ADVANTAGES & BENEFITS:

- Welding process automation
- Increase efficiency and production rate
- Replace time-consuming labour of a couple of welders
- Ensure high-quality welding seams with regular repetitiveness
- Enable multi-layer seams
- Improve working conditions and operator's safety
- Dimensions of gantry and track are tailored to customers' requirements

