

## ■ RAIL BULL | TRACK WELDING TRACTOR WITH OSCILLATOR

The Rail Bull is a track welding tractor designed to produce butt and fillet welds with or without oscillation.

The tractor can work in PA (flat), PB (horizontal vertical), PC (horizontal), PD (overhead horizontal-vertical), PE (overhead), PF (vertical-up) and PG (vertical-down) welding positions.



### ■ Applications:

- Trailer manufacturing
- Truck tanks
- Oil tanks
- Water storage tanks
- Pressure vessels
- Vessel overlay/Hard facing
- Bridge girders
- Structural steel
- Structural towers
- Panel welding
- Transformers
- Shipyards
- Any application demanding long, continuous welds

Rail Bull moves along either rigid or semi-flexible track on both ferromagnetic and non-ferromagnetic materials thanks to rack and pinion drive and tracks fixed to flat or curved surfaces by means of various magnetic or vacuum units. The minimum curvature radius required for semi-flexible track is 5 m (16 ft).



Continuous welding



Horizontal speed 0-120 cm/min



Vertical speed 0-110 cm/min



Linear oscillation with trapezoid and straight line paths

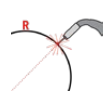

Min. path convex radius 5000 mm



Min. path concave radius 5000 mm

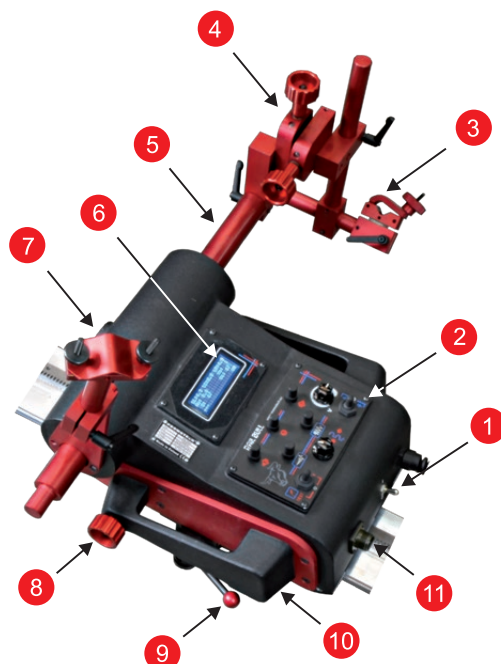
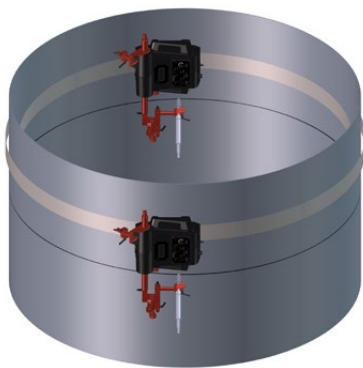
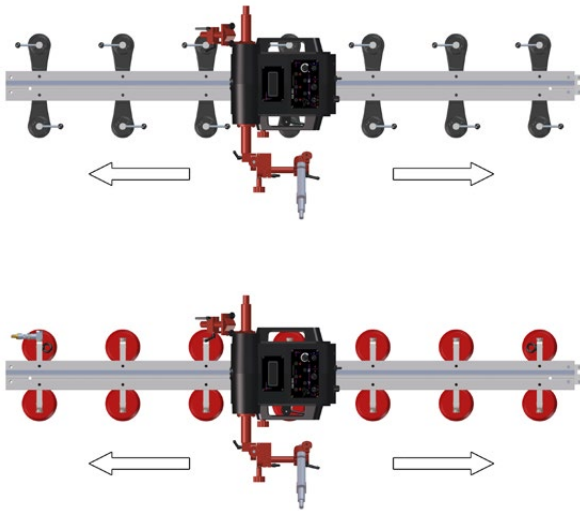

1. Power switch
2. Control panel
3. Torch holder with clamp
4. Cross slide assembly
5. Oscillator arm
6. Display
7. Cable anchor
8. Drive clutch knob
9. Mounting lever
10. Carrying handle
11. Arc ignition socket

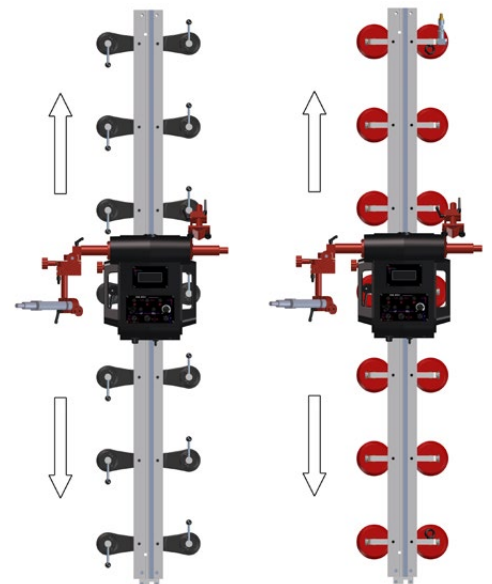



## ■ Primary features and benefits:

- Compact, lightweight design with durable aluminum cast housing
- Convenient Power Supply 115-230 V, 50-60 Hz or 42 V, 50-60 Hz
- Quick clamping torch holder mechanism for different types of MIG/MAG torches with diameters of 16-22 mm (0.63-0.87"); up to 35 mm (1.38") option
- Precise torch adjustment with screw drive cross slide
- Ready to work in both vertical and horizontal positions
- Multifunctional LED display (process parameters & warnings)
- Consistent heat input reduces distortion
- Reduce wasted filler metal - eliminates over welding
- Automatic arc on/off initiates welding and travel, simultaneously
- Closed-loop position control system based on electric motor with encoder - ensures increased accuracy of speed and positioning
- Improves working environment - removes operator from heat and fumes
- Linear torch oscillator to produce weave welds
- Menu in English (other languages on request)
- Rack and pinion drive
- Continuous welding
- Rigid rail track system

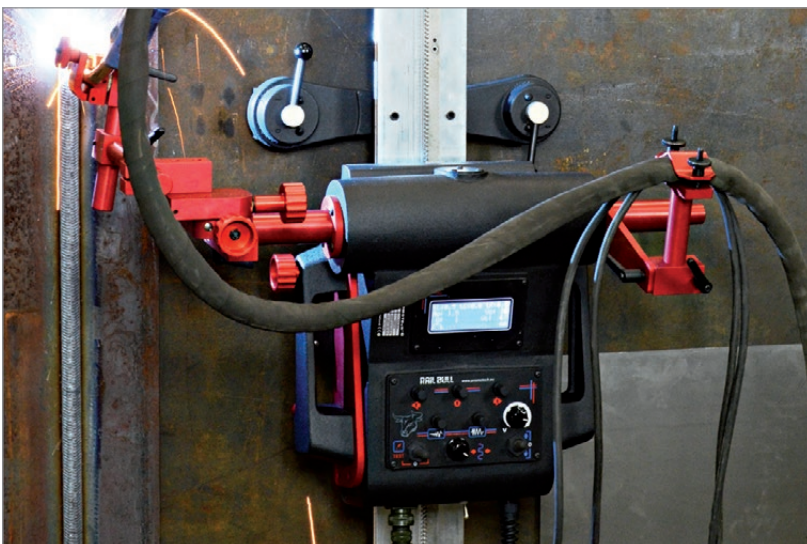
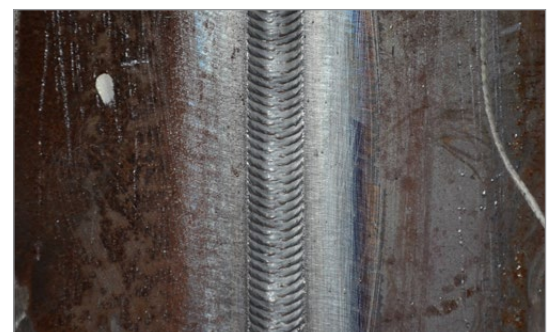

## TECHNICAL SPECIFICATIONS RAIL BULL

Voltage	1~ 115-230 V, 50-60 Hz 42 V, 50-60 Hz
Power	100 W
Welding position (according to EN ISO 6947 and AWS/ASME)	PA / 1F / 1G PB / 2F PC / 2G PD / 4F PE / 4G PF / 3G PG / 3G
Torch diameter	16-22 mm (0.63-0.87"); up to 35 mm (1.38") option
Minimum radius of curved workpiece surface	5000 mm (16 ft)
Minimum workpiece thickness	5 mm (0.2")
Horizontal pulling force	350 N
Vertical pulling force	150 N
Cross slide adjustment range	0-35 mm (0-1.38") up-down, left-right
Horizontal speed	0-120 cm/min (0-47.2 in/min)
Vertical speed	0-110 cm/min (0-43.3 in/min)
Weight	20 kg (44 lbs)
Welding settings storage	1 (last used)
Oscillation type	linear (0 - 100 mm)
Oscillation (weaving) pattern	trapezoid, straight line
Oscillation width	0-50 mm (0-1.9")
Oscillation speed	0-1500 mm/min (0-59 in/min)
Oscillation delay time	0-5 s (at external and central points)
Product Code (115-230 V, 50-60 Hz, plug EU)	WOZ-0482-10-20-01-0
Product Code (115-230 V, 50-60 Hz, plug UK)	WOZ-0482-10-10-01-0
Product Code (42 V, 50-60 Hz)	WOZ-0624-10-04-00-0

### Weld paths:

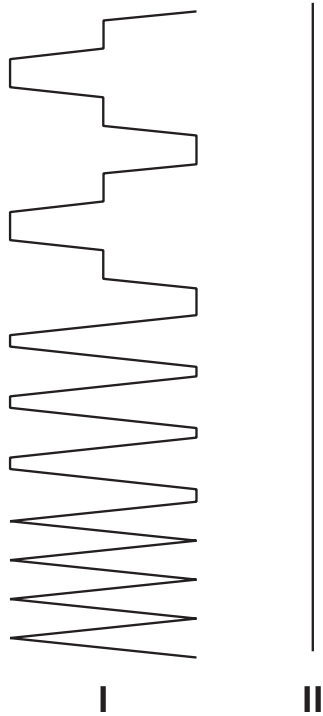

- I. Trapezoid The tractor travels continuously even during dwell mode. Weld path is determined by weave speed and dwell time at center and on sides of the weld path.
- II. Straight The tractor travels continuously while oscillation is switched-off.

### Dimensions:

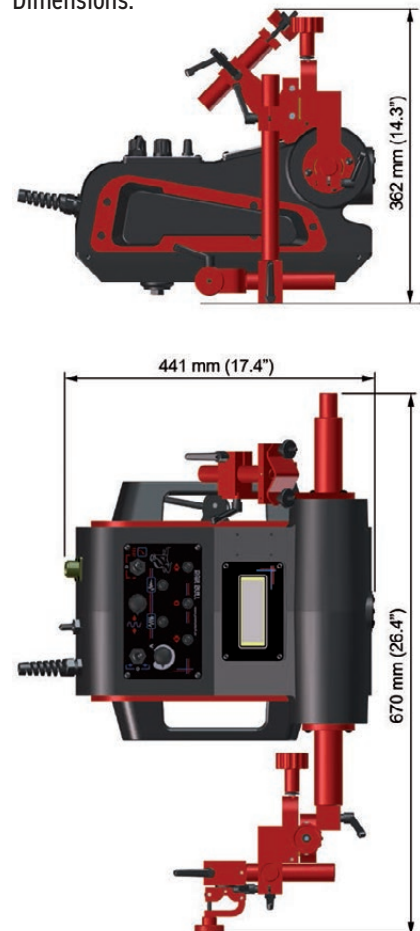

**Standard accessories:**



Power Cord 3m (10 ft)



Dual Arc Ignition Cable of 6.5 m (21 ft)  
KBL-0466-17-00-00-0



Torch Holder Short Rod Clamp Assembly  
UCW-0476-20-00-00-0



Cable Anchor  
UCW-0482-17-00-00-0



Cross slide assembly  
PRW-0482-11-00-00-0

**Optional accessories for variety of applications:**



Rigid track length 2 m (6.5 ft)  
PRW-0482-47-00-00-0



Bracket for magnetic unit  
for rigid track  
DYS-0482-21-00-00-0

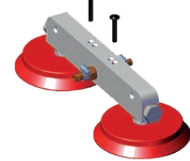

Vacuum modular unit  
MST-0541-10-02-00-0



Magnetic narrow unit  
with hexagon  
PDS-0582-10-00-02-0



Magnetic unit  
ZSP-0475-92-00-00-0



Lightweight Dual  
Magnetic Unit  
MST-0677-00-00-00-0



Heat-resistant  
magnetic unit  
ZSP-0475-93-00-00-0

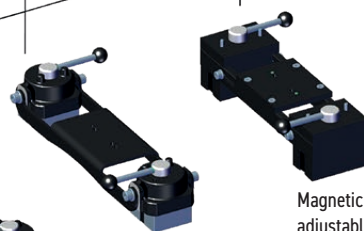

Magnetic spacing-  
adjustable unit  
ZSP-0523-19-00-00-0



Magnetic pivoting unit  
ZSP-0475-85-00-00-0

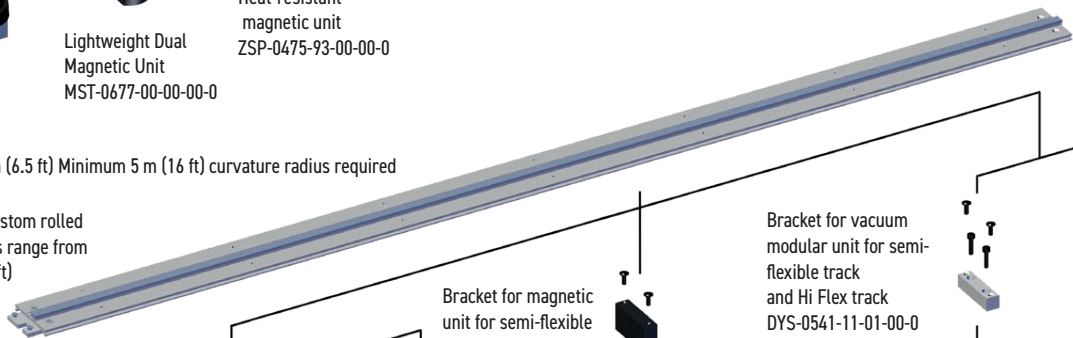

Semi-flexible track length 2 m (6.5 ft) Minimum 5 m (16 ft) curvature radius required  
PRW-0482-15-05-00-0

Semi-flexible tracks can be custom rolled permanently within the radius range from 1.5 m up to 5 m (5 ft up to 16 ft)



Bracket for magnetic unit for  
semi-flexible track  
and Hi Flex track  
DYS-0482-19-00-00-0

Bracket for magnetic  
narrow unit for  
semi-flexible track  
and Hi Flex track  
DYS-0582-10-00-00-0

Bracket for magnetic  
unit for semi-flexible  
track  
and Hi Flex track  
DYS-0482-19-00-00-0

Bracket for vacuum  
modular unit for semi-  
flexible track  
and Hi Flex track  
DYS-0541-11-01-00-0

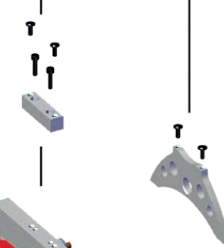

Aluminum track  
support for semi-  
flexible track  
WSP-0541-11-02-00-0



Vacuum modular unit  
MST-0541-10-02-00-0

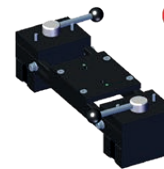

Magnetic spacing-  
adjustable unit  
ZSP-0523-19-00-00-0



Magnetic pivoting unit  
ZSP-0475-85-00-00-0



Steel track support for  
semi-flexible track  
WSP-0523-12-01-00-1



Magnetic narrow  
unit with hexagon  
PDS-0582-10-00-02-0



Magnetic unit  
ZSP-0475-92-00-00-0



Lightweight Dual  
Magnetic Unit  
MST-0677-00-00-00-0



Heat-resistant  
magnetic unit  
ZSP-0475-93-00-00-0







Gear Rack Adjustment Tool  
PKT-0341-13-00-00-0

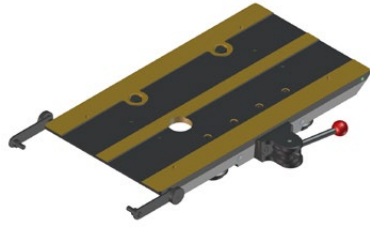

Transport Attachment  
PEP-0482-18-00-00-0



16-22 mm Torch Clip  
ZCS-0476-06-01-00-0



22-35 mm Torch Clamp  
ZRZ-0466-19-00-00-0



Rail Bull is suitable for work in both horizontal and vertical positions

The Rail Bull welding tractor is supplied in a metal box including:

- welding tractor
- metal box
- cross slide assembly
- short rod torch holder with clamp
- cable anchor
- power cord 3 m (10 ft)
- arc ignition cable of 6.5 m (21 ft)
- 3 mm hex wrench
- 4 mm hex wrench
- operator's manual

More information available at [www.promotech.eu](http://www.promotech.eu)



Rail Bull features  
User-friendly  
control panel



**American Welding Society**  
Supporting Company Member

Mitglied im DVS – Deutscher Verband für  
Schweißen und verwandte Verfahren e. V.



All information is subject to change without notice. 20.11



PROMOTECH Sp. z o.o.  
ul. Elewatorska 23/1, 15-620 BIAŁYSTOK, POLAND  
tel. (+48 85) 678 34 05, fax (+48 85) 662 78 77  
marketing@promotech.eu www.promotech.eu

Your local dealer:

